



# Boulder County Land Use Department

2045 13th Street • P.O. Box 471  
Boulder, Colorado 80306  
303.441.3930

## Emergency Access and Water Supply

Emergency personnel try their best to respond to calls in a timely manner, often while negotiating difficult terrain. Planning for access by emergency equipment allows for a more efficient response, improving safety for homeowners and their families, as well as the firefighters and emergency medical technicians that may arrive on the scene. This is especially important in rural areas where response times may be considerably longer than in cities, where emergency services are close by.

### ACCESS GUIDELINES

#### Driveway Turn-Arounds

Driveway turn-arounds may be required as part of Site Plan Review, for driveways that are 150 feet or more in drivable length from the public or private road. Turn-arounds, unobstructed by parking, are designed and constructed to allow for safe reversal of direction by emergency equipment. The "Y" and "Hammerhead" turn-arounds shown below are preferred by the County because they provide the necessary access while minimizing disturbance to the site.

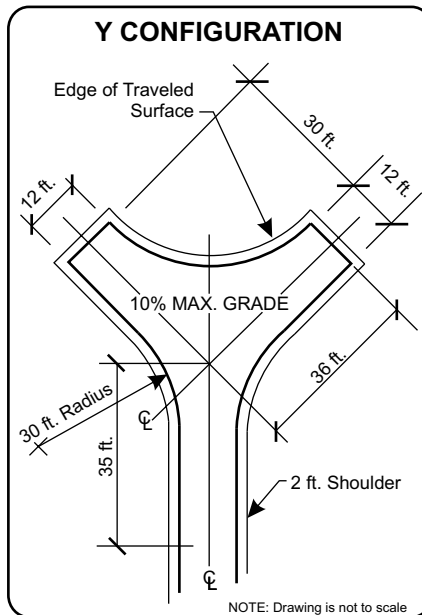
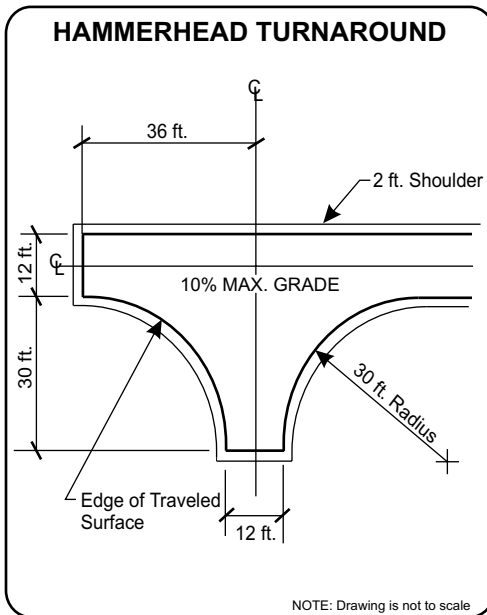

**BRIDGE LOAD LIMITS**  
The load limits for a bridge shall be posted at both entrances of the bridge.

**DRIVEWAY WIDTH & HEIGHT**  
Design your driveway to have an unobstructed vertical clearance of 13 feet, 6 inches. You may need to limb trees or bury utility lines to provide necessary clearance.  
Design your driveway with a 12 foot wide driveable surface and 14 feet clear of obstructions.

**ADDRESS SIGNS**  
All buildings shall have a permanently posted, Boulder County issued, green and white address sign. This sign shall be placed and permanently maintained at each driveway entrance. The address sign must be visible from both directions of travel along the main road or access route.  
Address signs will be mailed to you within six months of building permit application. If you do not receive your sign within this timeframe, please contact the Land Use Department at 303.441.3930.

#### Driveway Pull-Outs

Driveway pull-outs are designed with sufficient length and width to allow emergency vehicles to pass one another during emergency operations. These features should be placed at 400 foot intervals along the driveway. The location of the pull-out(s) can be modified to accommodate physical barriers such as rock outcrops, wetlands, and other features.

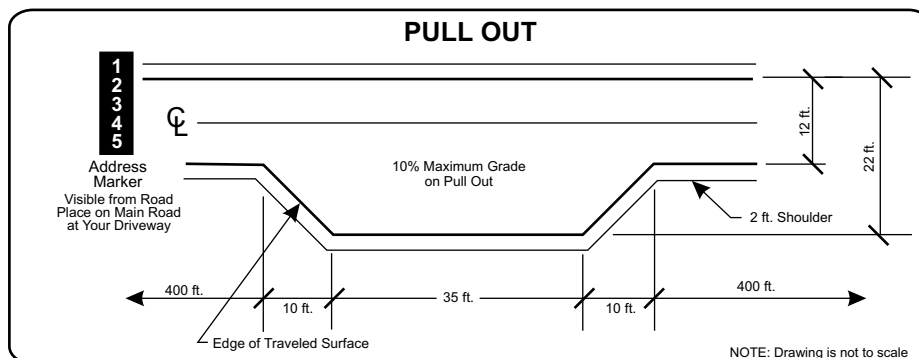

## FIRE PROTECTION DISTRICTS

The Land Use Department relies on local Fire Protection Districts (FPD's) to inform us about emergency service for projects under review. It's always helpful to discuss your project with your local FPD before you submit for any Land Use review. This will help determine what kind of access and water supply will work best for your site. Ultimately, it is the Land Use Department which places the actual emergency access requirements on projects. These requirements may differ somewhat from the FPD's suggestions, primarily because while the FPD can focus their comments only on the emergency service requirements, the Land Use Department must address a wide range of issues. The purpose of this handout is to provide applicants with some basic guidelines which, from our experience, are the preferred options in the Site Plan Review, Limited Impact Special Use Review, and Special Use Review processes.

## CISTERNS

Once the emergency vehicles arrive at your site, they may need a dependable supply of water to help control a fire. An operational well is not enough water for fire control. A cistern may be required.

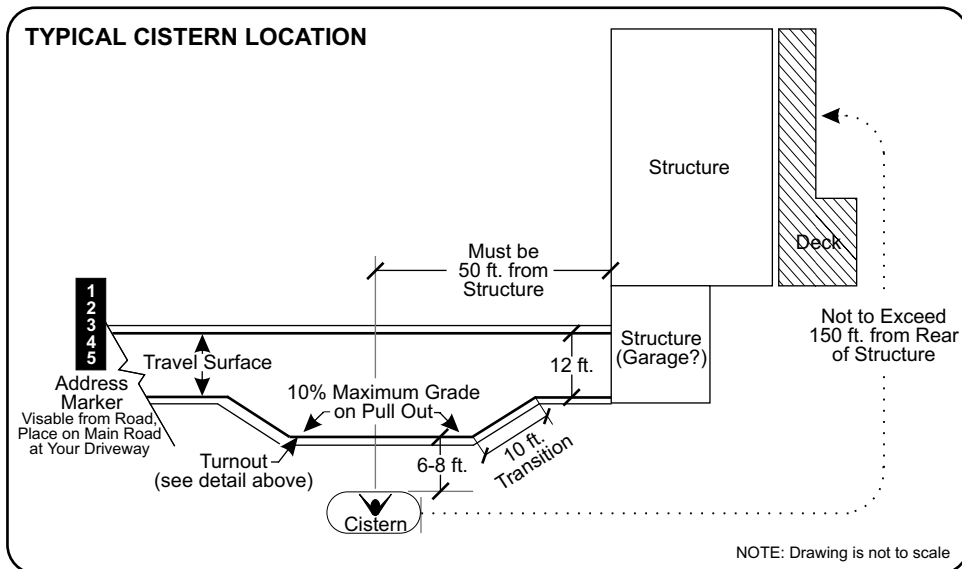

### WATER SUPPLY OPTIONS

If your project is within the mountainous region of the County, the Land Use Department will typically require one of the following water supply options, accepted by most Fire Departments:

An on-site 1,800 to 2,500 gallon cistern

A monetary contribution to a community cistern fund

A "dry hydrant" to be installed in a nearby pond, lake or stream (*please contact our Wildfire Mitigation Coordinator for specifications*).

For more information about These standards or about the County's fire management efforts, please contact:

Eric Philips

Wildfire Mitigation Coordinator

303.441.3930

Fax: 303.441.4856

[ephilips@co.boulder.co.us](mailto:ephilips@co.boulder.co.us)

Office hours:

Monday thru Friday

8:00 AM to 4:30 PM

Or

contact your

local fire protection district

Visit Land Use Departments

Web Site:

<http://www.co.boulder.co.us/lu/>