

UW SPACE WAGGONEERS A.T.C.H



ADJUSTABLE TOOL CART HANDLE



NASA Micro-g NExT Challenge

2025-2026

Team Members: Brady Kufeldt, Zeke Werner, Holden Eigenberger, Andrew McLeod, and Matas Katieb

NASA Micro-g NExT Competition

Micro-g Neutral Buoyancy Experiment Design Teams (Micro-g NExT) challenges undergraduate students to design, build, and test a tool or device that will aid in the exploration of the Moon and Mars during NASA's Artemis Mission.

Project Description

- Improve astronaut mobility during lunar Extravehicular Activities (EVA).
- Replace traditional, fixed cart handle with an ergonomic, adjustable solution.
- Address limitations of EVA suits including motion restriction, reduced grip strength, and limited dexterity.

Design Requirements

- Manual actuation only
- Maintain function under dust exposure
- Adjust height between 37"-45" from the ground
- Mass limit < 5lb
- Bending/deflection factor of safety > 2 under a max load of 70lbf on Earth
- Constructed from NBL-approved materials
- No sharp edges or pinch points within NBL guidelines
- Must sink in water

Final Design

- Pitch joint to adjust height within 37-45"
- Bike brake lever located on handlebar to actuate the sliding locking plate featured in *Figure 2*
- Locking positions allow for the handle to lock while folded, fitting into a 16"x16"x20" space.
- Full Assembly visible in *Figure 1*, locking mechanism in *Figure 2*, 3D printed parts in *Figure 3*, pitch joint pieces in *Figure 4*.

Materials

- 6061 T6 aluminum is the primary stock material used for machined components.
- Carbon fiber reinforced nylon filament for 3D printed parts.
- Majority stainless steel hardware

Notable Components

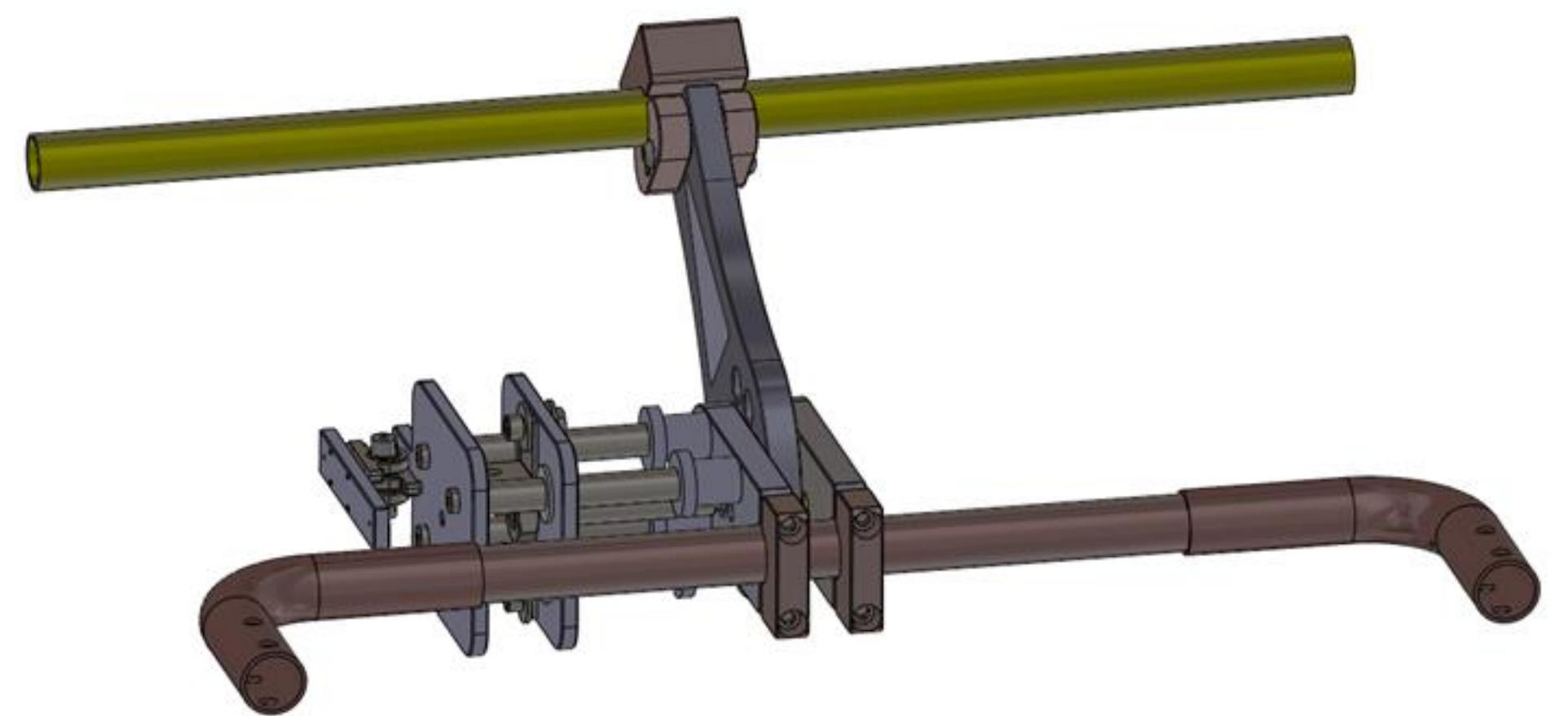

Figure 1: Full A.T.C.H model

Sliding Plate

Locking Pin

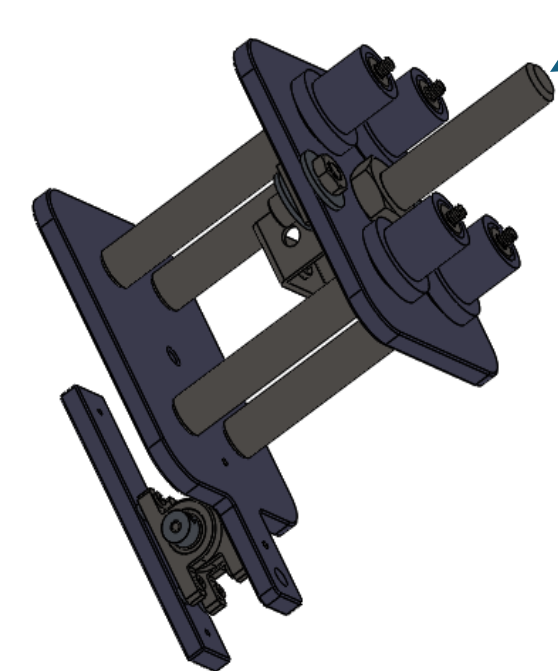
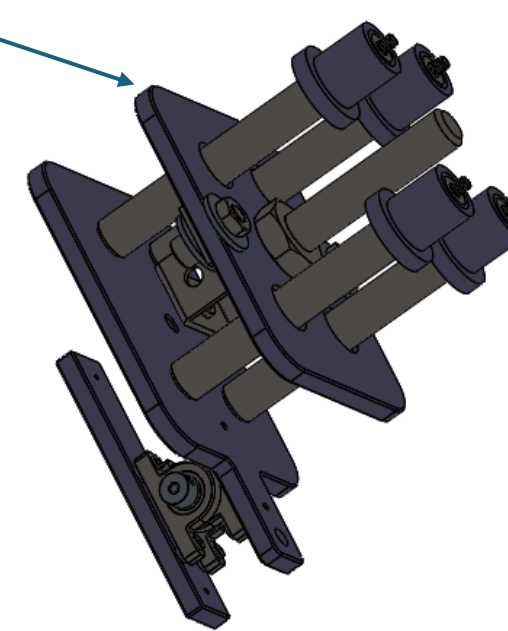

Figure 2a: Unlocked Position

Figure 2b: Locked Position

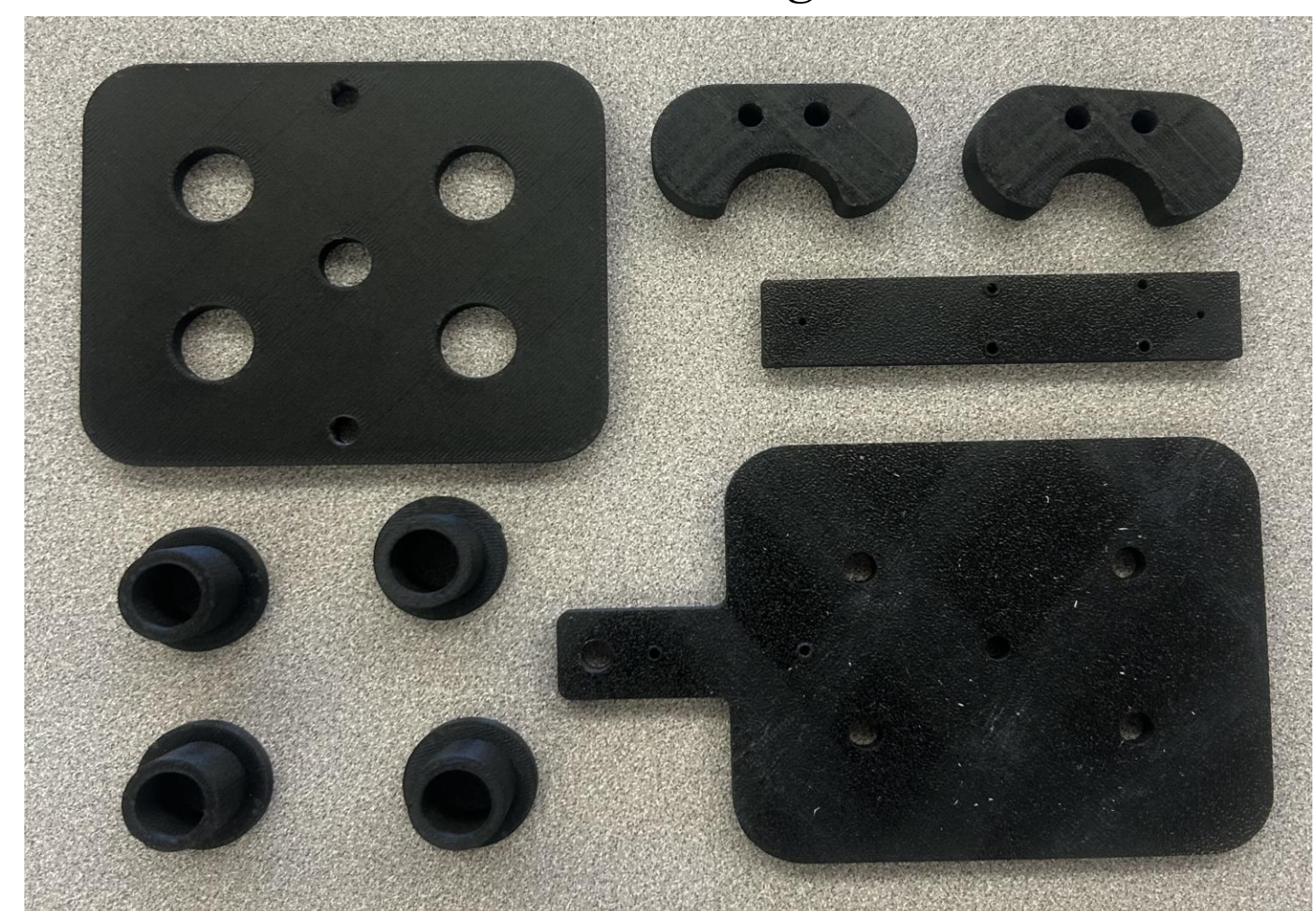

Figure 3: 3D printed parts, including the lever, sliding plates and spacers for the locking mechanism and width extenders for the handlebar clamp.



Figure 4: Manufactured pieces of the pitch joint to include the center section with locking positions and side pieces with standoff and pivot holes.