

TYPE II DELINEATOR

(TYP. INTERSTATE SHOULDERS, RAMPS & APPROACHES)
 TYPE IIV = WHITE
 TYPE IIV = YELLOW

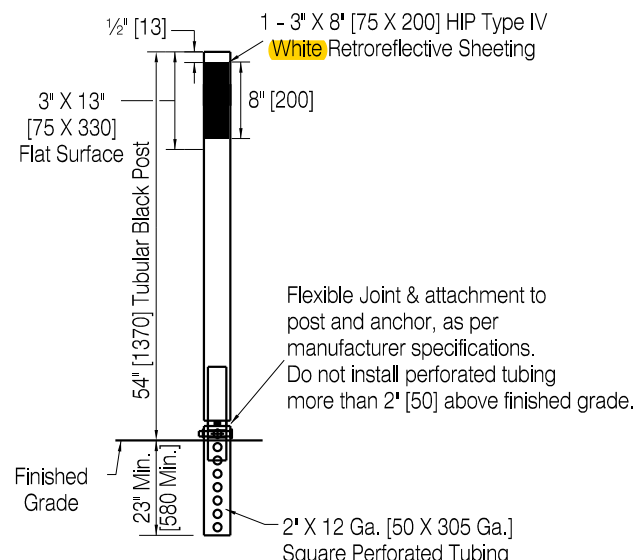

TYPE III DELINEATOR

(TYP. TWO-WAY ROADWAYS)

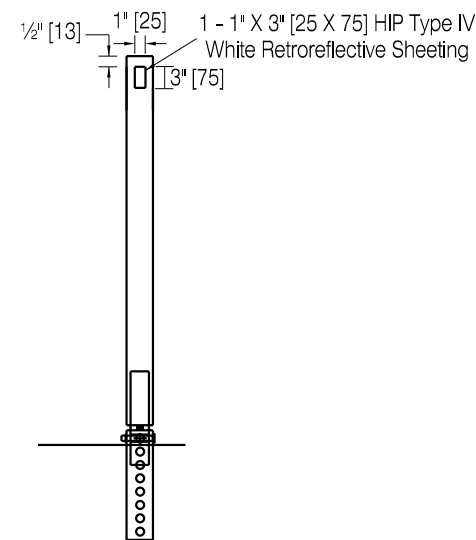

BACK VIEW

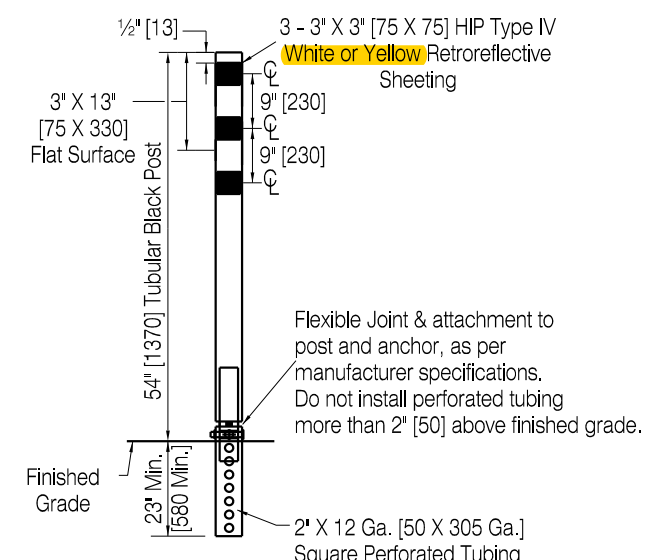

TYPE IV DELINEATOR

(WHITE, OUTSIDE SHOULDERS INTERSTATE, SPECIAL LOCATIONS, YELLOW, HAZARD LOCATIONS & OFF RAMP ENTRANCE)

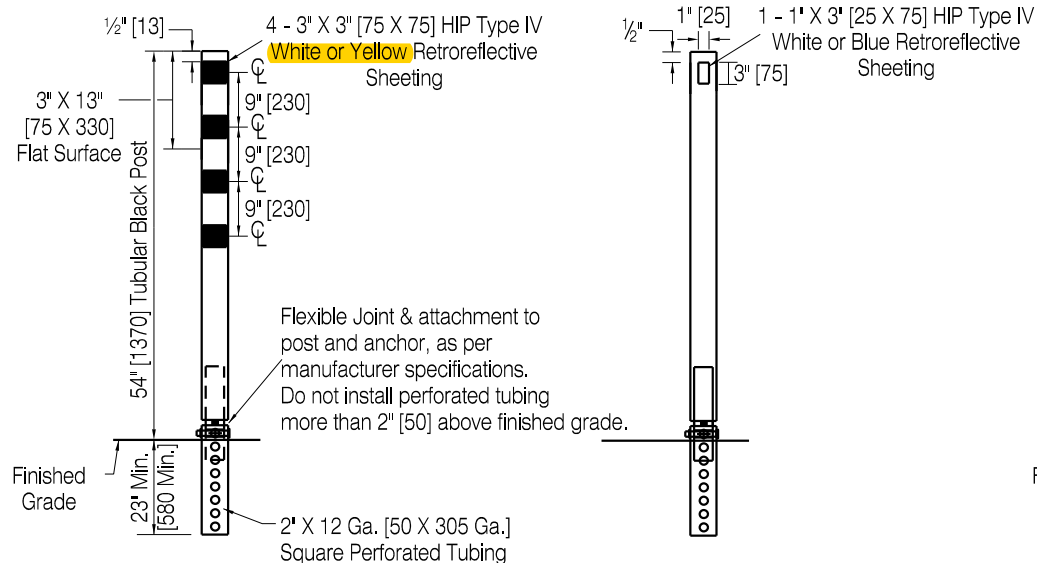

TYPE V DELINEATOR

(TYP. MEDIAN CROSSOVERS)

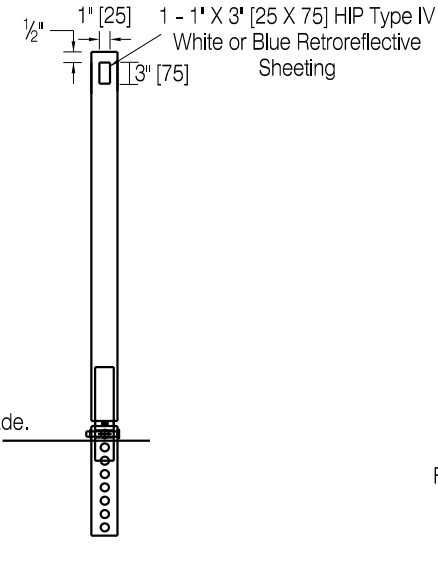

BACK VIEW

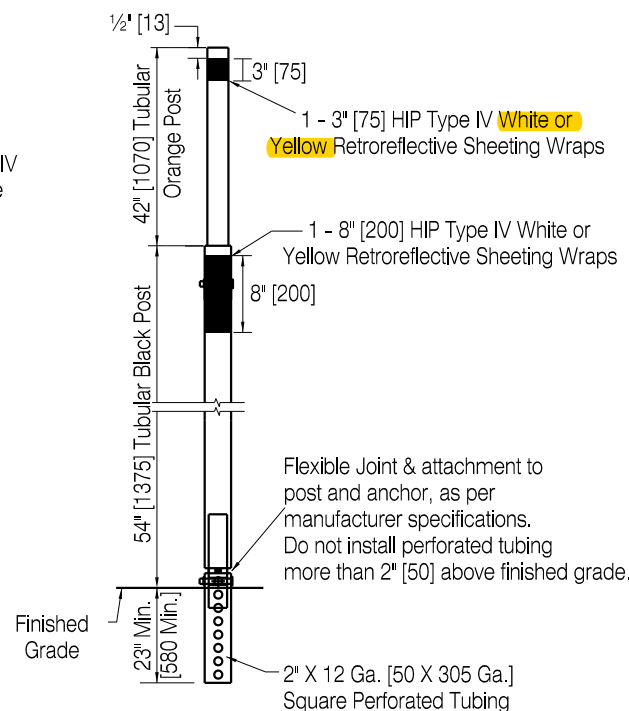

**TYPE VII DELINEATOR
96" SNOW-POLE**

(TYP. SHOULDERS AND APPROACHES, HEAVY SNOW AREAS)

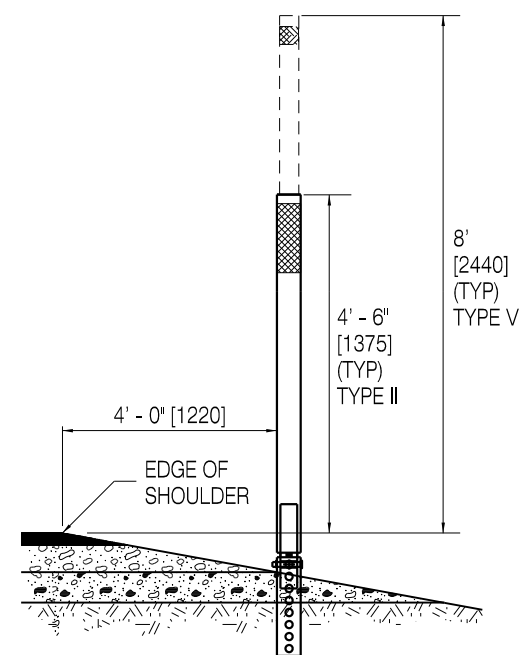

TYPICAL PLACEMENT

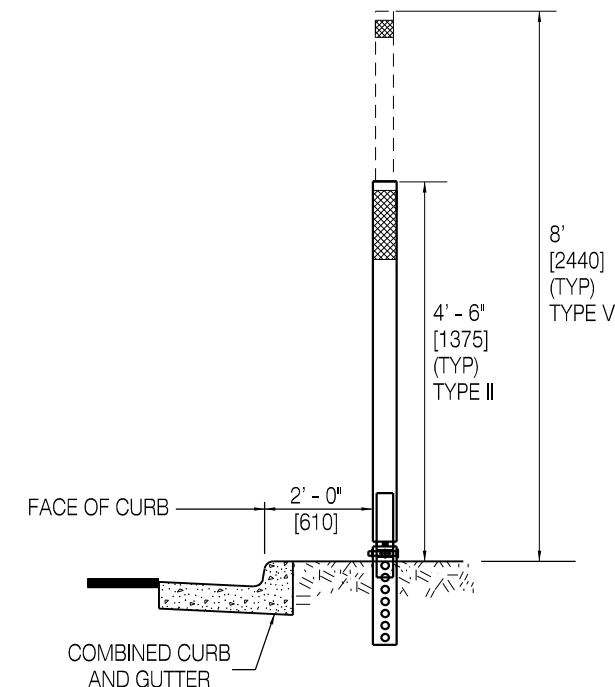

TYPICAL PLACEMENT-RURAL SECTIONS WITH CURB & GUTTER W/O SIDEWALK

DELINEATOR TYPES

Orient delineators as shown above as viewed by traffic approaching in lane immediately adjacent to the delineator.

Designed by: TRAFFIC
 Drawn by: JTG
 Checked by: TRAFFIC
 Previous Dwg. No. 702-1B

FLEXIBLE DELINEATORS



DELINEATORS

STANDARD PLAN NUMBER
702-1C
 SHEET 2 of 3
 Issued by: TRAFFIC PROGRAM
 Date Issued: FEBRUARY, 2026

Note: Units shown in brackets [] are metric and are in millimeters (mm) unless other units are shown.

STANDARD PLAN

